

3660 & 4000 Chamber Units

Installation Instructions

General

All units are produced and tested where possible in accordance with the relevant provisions of BS EN 1917/BS 5911-3 (but are not kitemarked).

The chamber sections are supplied with lifting points for the attachment of Marshalls CPM lifting brackets only.

Chamber units can be supplied with or without double step rungs or with the integrated ladder system.

Advantages of system include:

- **Smooth bore requiring no secondary lining**
- **Fewer joints than a segmental shaft**
- **Less sealant required**
- **Fewer connecting bolts than a segmental shaft**
- **Speedy installation**



Chamber units

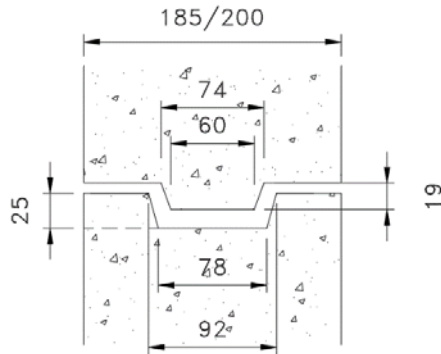

| <u>Chamber section</u> | <u>Wall thickness</u> | <u>Approx weight of half chamber section</u> | <u>Approx weight of sections when jointed</u> |
|------------------------|-----------------------|----------------------------------------------|-----------------------------------------------|
| <u>DN</u> | <u>mm</u> | <u>kg per m</u> | <u>kg per m</u> |
| 3660 | 185 | 2650 | 5300 |
| 4000 | 200 | 3180 | 6360 |

Chamber sections are supplied with a tongue and groove joint. Lifting brackets and bolts for handling and installation purposes can be purchased from Marshalls CPM.

Components

1. Chamber units are available in 1.00m and 0.75m depths.
2. Connecting bolts and sealant for both vertical and horizontal joints.

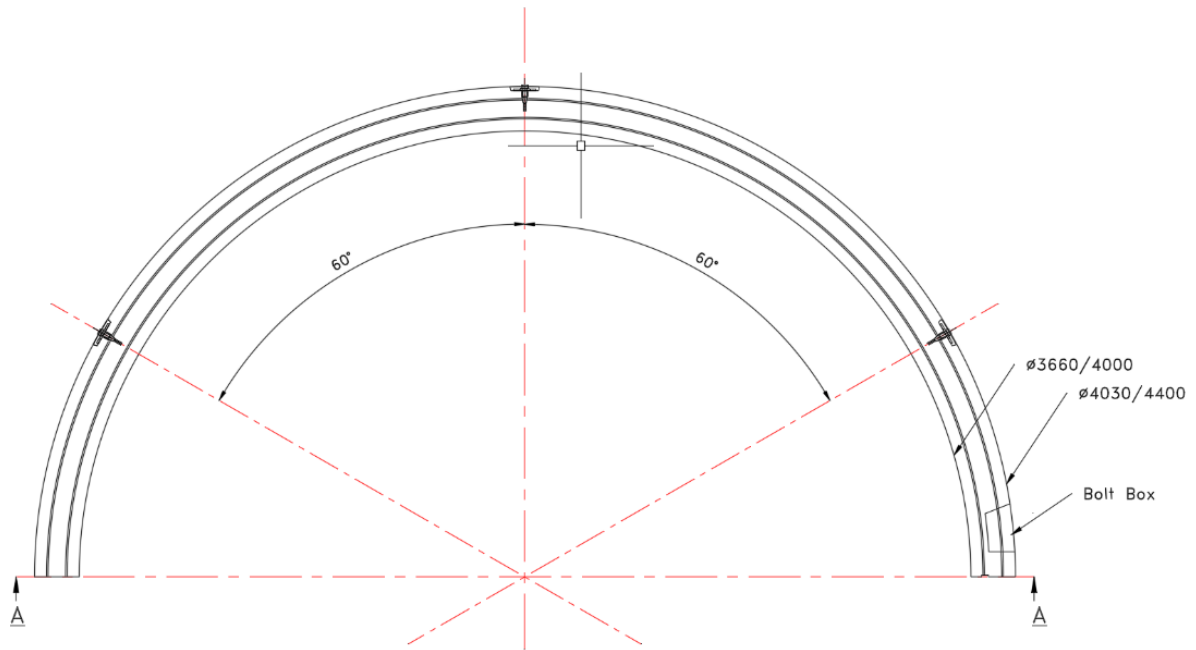

PLAN VIEW

3No bolt boxes in 1.00m deep unit, boxes set at 215mm, 600mm and 855mm from top of unit.

2No bolt boxes in 0.75m deep unit boxes set at 215mm and 600mm from top of unit.

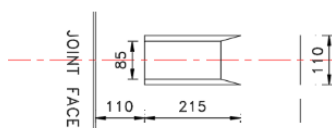

JOINT - ELEVATION

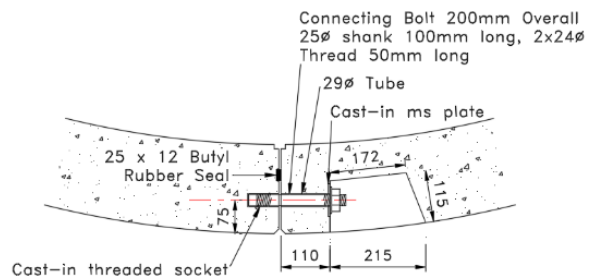

JOINT - PLAN

Cover slabs

| <u>Heavy duty cover slab</u> | <u>Effective thickness</u> | <u>Overall thickness</u> | <u>Overall diameter</u> | <u>Approx weight of complete slab (total of 2 parts)</u> |
|------------------------------|----------------------------|--------------------------|-------------------------|----------------------------------------------------------|
| <u>DN</u> | <u>mm</u> | <u>mm</u> | <u>mm</u> | <u>tonne</u> |
| 3660 | 275 | 300 | 3960 | 8.50 |
| 4000 | 275 | 300 | 4500 | 10.95 |

- Heavy duty cover slabs are manufactured in two sections, and can be supplied with a 600mm, 675mm square or 900mm x 600mm access with chamfered corners.
- Each section is provided with a minimum of 3 lifting points. Customer to supply and lift with suitable hook and chain sets.
- The cover slabs are designed to BS EN 1992-1-1, loading to BS EN 1991-2: Cl 4.3, LM1-3, concrete strength C40/50, exposure class XD3 top face & XC3/4 bottom face, exposure condition: very severe (BS8110-1), cover: Cmin = 45mm/Cnom = 50mm.
- Cover slabs with non-standard access, rebated, multiple access, with davit sockets etc. are made to order.

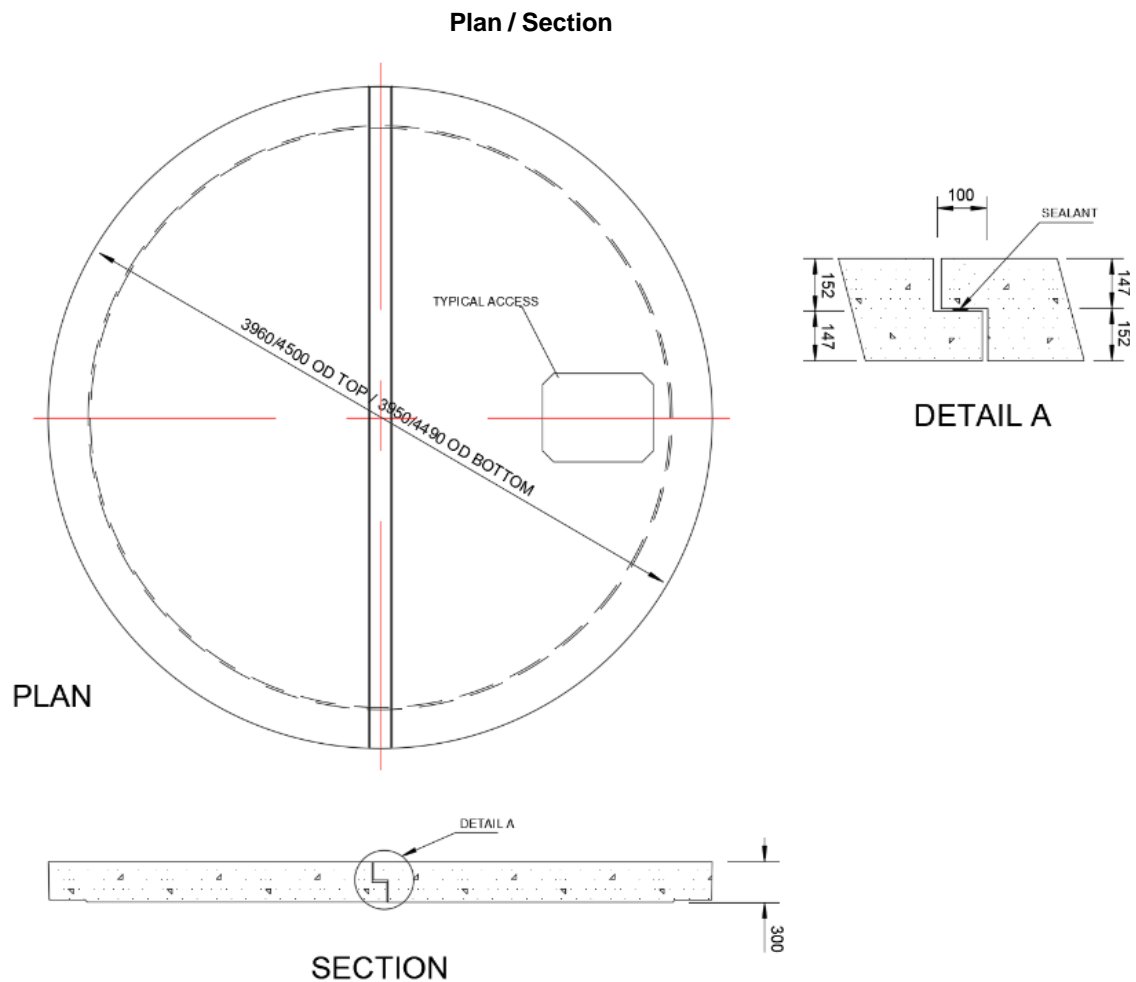



A Components

1. Ensure the contents of each load are carefully checked against the delivery note.
2. The connecting bolts, nuts and washers should be stored in a secure area until required.
3. The boxes of butyl sealant should be stored in a dry secure area until required. Each horizontal joint requires approximately three boxes and each 1m vertical joint requires approximately one quarter of a box.



B. Lifting

1. Ensure suitable craneage and lifting attachments are available for offloading and placing of shaft. It is recommended that a full circle slew type machine is used for handling, jointing and positioning shaft sections.

A three legged chain of minimum 4 metre length must be used.

2. Each 1m chamber section weighs approximately 2.65/3.18 tonnes (DN3660/DN4000 units respectively). The combined weight of the unit when jointed being 5.30/6.36 tonnes (DN3660/DN4000 units respectively).

C. Procedure

The principal of the system is to joint two half sections of chamber ring at ground level, and then lower the complete unit into the prepared shaft.

1. Ensure a safe working area of approximately 6 square metres is designated for jointing the sections away from the shaft and that the ground is level.
2. Lower the first half section on to timber bearers, ensuring the bearers at the vertical joint faces are set back to allow access for a minimum of 50mm overlap to top and bottom of the horizontal joint faces when placing the 25mm x 12mm butyl sealant.
3. Screw the connecting bolts into the cast in threaded sockets provided on the vertical joint faces.
4. Place the 25mm x 12mm butyl sealant, as supplied by Marshalls CPM, along the vertical groove provided, allowing approximately 50mm overlap to the horizontal joints both top and bottom.





5. Offer up the second segment to the first with the crane just taking the weight (**it is essential that the crane takes the load until such time as the jointing operation has been completed and the whole unit is evenly supported from below**).

6. Engage all of the 200 x 24mm dia bolts provided and pull the segments together by tightening each bolt gradually and in turn ensuring that the segments remain level. A tirtor may be used to winch the units together if necessary.



7. The bolts should be tightened to compress the seal to give a 6-8mm joint gap. A maximum torque of 125Nm should be applied. If due to adversely cold conditions the seal cannot be compressed within the torque limit, apply gentle heat to the seal to soften it.

8. Place supporting bearers under second section having jointed the two halves together. Ensuring the connecting bolts are tight, release the lifting chains.

9. Place the 75mm x 12mm butyl sealant, supplied by Marshalls CPM around the locating groove of the horizontal joint and over the 50mm overlap from the vertical face.

10. Utilising three of the six lifting points provided when the sections are jointed, attach 3 of the Marshalls CPM lifting brackets and connect lifting chains. Lift as complete unit and lower into shaft.



11. Repeat the above process for additional units to be placed, but ensure the subsequent units are turned through 90 degrees when lowering into the shaft, thereby staggering the vertical joints.

12. Caulking grooves are provided at the inside edges of every vertical and horizontal face to allow for the provision of additional sealant if required.

13. The butyl sealant can be used on the base joint and the top joint of the cover slab for sealing purposes.

14. The cover slab is supplied in two sections. 25mm x 12mm butyl sealant can be used on the rebated lip of the sections prior to placement to provide a watertight seal.

15. In the case of deep shafts or where a high water table exists, it is recommended that a secondary sealant be used to ensure water tightness at the joints. e.g. hydrophilic material.

